



**ISClass**

**GUIDELINES FOR SURVEY OF  
ANTI-FOULING SYSTEMS ON SHIPS**

**2023**

Effective from 1 February 2023

## CONTENTS

<b>CHAPTER 1 GENERAL.....</b>	<b>1</b>
1.1 Purpose and application.....	1
1.2 Definitions.....	1
1.3 Requirements for controls on anti-fouling systems on ships.....	2
1.4 Class notation.....	3
<b>CHAPTER 2 SURVEY OF SHIPS .....</b>	<b>4</b>
2.1 General requirements .....	4
2.2 Request for survey.....	4
2.3 Initial surveys.....	5
2.4 Additional surveys.....	6
<b>CHAPTER 3 ANTI-FOULING SYSTEM CERTIFICATE.....</b>	<b>8</b>
3.1 Issuance and endorsement of certificate.....	8
3.2 Expiry and revalidation of certificate.....	8
<b>ANNEX 1 METHODS FOR SAMPLING AND ANALYSIS OF ANTI-FOULING SYSTEMS.....</b>	<b>9</b>
<b>ANNEX 2 AMENDMENTS TO THE INTERNATIONAL CONVENTION ON THE CONTROL OF HARMFUL ANTI-FOULING SYSTEMS ON SHIPS, 2001... </b>	<b>32</b>

## CHAPTER 1 GENERAL

### 1.1 Purpose and application

1.1.1 The Guidelines are intended to stipulate relevant requirements for surveys of anti-fouling systems on ships and ensure that ships and applied anti-fouling systems comply with applicable specified requirements.

1.1.2 The Guidelines are applicable to surveys in the following cases:

- (1) surveys of ships applying for issuance and/or endorsement of an anti-fouling system certificate;
- (2) surveys of ships applying for ISC “AFS/AFS+” class notations of environmental protection sub-elements for green eco-ships.

### 1.2 Definitions

1.2.1 For the purpose of the Guidelines, relevant terms are defined as follows:

(1) “*Anti-fouling system*” means a coating, paint, surface treatment, surface, or device that is used on a ship to control or prevent attachment of unwanted organisms.

(2) “*Specified requirements*” mean the following convention, rules and other accepted standards:

- ① IMO International Convention on the Control of Harmful Anti-Fouling Systems on Ships, 2001 (hereinafter referred to as “the AFS Convention”) and its amendments (Appendix 2 of the Guidelines);
- ② ISC Rules for Green Eco-ships;
- ③ applicable requirements of the flag State or regional directives (e.g. REGULATION (EC) No.782/2003 and its amendments).

(3) “*Anti-fouling system certificate*” means a formal document showing compliance of the anti-fouling system applied to the ship with relevant specified requirements. The certificate is to be drawn up in the common form, the EU form or the CHN form as follows:

- ① The common form consisting of:
  - a. International Anti-Fouling System Certificate (Form CAF) and Record Book of Anti-Fouling Systems (Form RAF), which are applicable to all ships, other than those flying the flag of China, flying the flag of the flag States that have accepted the AFS Convention;
  - b. Statement of Compliance of Anti-Fouling Systems (Form SAF) and Record Book of Anti-Fouling Systems (Form RAF), which are applicable to ships flying the flag of a non-EU Member State that has not accepted the AFS Convention.

- ② EU form of International Anti-Fouling System Certificate (Form CAF(EU)) and Record Book of Anti-Fouling Systems (Form RAF), which are applicable to ships flying the flag of an EU Member State that has not accepted the AFS Convention.
- ③ CHN form of International Anti-Fouling System Certificate (Form CAF(CHN)) and Record Book of Anti-Fouling Systems (Form RAF(CHN)) , which are applicable to ships flying the flag of China.

(4) “*Endorsement of AFS record books*” means a formal document for endorsing certificate records on completion of additional surveys of anti-fouling systems on ships. The EU form of endorsement of certificate records (Form RAF-E(EU)) is to be used for ships with EU form of certificate as defined in 1.2.1(3). The common form of endorsement of certificate records (Form RAF-E) is to be used for ships with common form of certificate. And the CHN form of endorsement of certificate records (Form RAF-E (CHN)) is to be used for ships with CHN form of certificate.

(5) “*Initial survey*” means a survey carried out for the assignment of ISC “AFS/AFS+” class notations of environmental protection sub-elements for green eco-ships and/or before the ship is put into service or when the International Anti-Fouling System Certificate or Statement of Compliance of Anti-Fouling Systems is issued by ISC on request for the first time, in order to confirm compliance with relevant specified requirements (1.2.1(2)).

(6) “*Additional survey*” means a survey carried out when an anti-fouling system of a ship is changed or replaced entirely, or when the scope of repairs affects 25% or more of the anti-fouling system, or when a ship undergoes a major conversion, excluding simple maintenance, such as touch-up painting after chafing the dock.

(7) “*Applicant*” means the owner, the shipbuilder or the company applying for the survey of anti-fouling systems on ships by ISC.

(8) “*Company*” means the owner of the ship or any other organization or person such as the manager, or the bareboat chartered, who has assumed the responsibility for operation of the ship from the owner of the ship and who on assuming such responsibility has agreed to take over all the duties and responsibilities imposed by the International Safety Management Code.

### **1.3 Requirements for controls on anti-fouling systems on ships**

1.3.1 The requirements for control of organotin compounds in anti-fouling systems:

(1) All ships are not to apply or re-apply organotin compounds which act as biocides in anti-fouling systems.

(2) For the existing ships (excluding fixed or floating platforms, floating storage units and floating production storage and off-loading facilities constructed before 1 January 2003 and not repaired in dock on or after 1 January 2003), the following two control measures are to be taken:

- ① harmful anti-fouling system containing organotin compounds, applied on/after 1 January 2003 or a later date if specified by the Administration, is to be removed;

- ② harmful anti-fouling system containing organotin compounds, applied before 1 January 2003 or a later date if specified by the Administration, is to be removed. Or ships are to bear a coating that forms a barrier to such compounds leaching from the underlying non-compliant anti-fouling systems.

(3) Small quantities of organotin compounds acting as a chemical catalyst (such as mono- and di-substituted organotin compounds) are allowed. On a practical level, when used as a catalyst, an organotin compound should not be present above 2,500 mg total tin per kilogram of dry paint.

#### 1.3.2 Requirements for controls on cybutryne<sup>①</sup> (CAS No.: 28159-98-0) of anti-fouling system:

(1) Ships are not to apply or re-apply anti-fouling systems containing cybutryne since 1 January 2023;

(2) Ships (except fixed and floating platforms, FSUs, and FPSOs that have been constructed prior to 1 January 2023 and that have not been in dry-dock on or after 1 January 2023) bearing an anti-fouling system that contains cybutryne in the external coating layer of their hulls or external parts or surfaces on 1 January 2023 are to remove the anti-fouling system or apply a coating that forms a barrier to cybutryne leaching from the underlying non-compliant anti-fouling system at the next scheduled renewal of the anti-fouling system after 1 January 2023, but no later than 60 months following the last application to the ship of an anti-fouling system containing cybutryne.

(3) Cybutryne in anti-fouling system are not to be present at a level which does provide a biocidal effect. When samples are directly taken from the hull<sup>②</sup>, average values of cybutryne are not to be present above 1,000 mg of cybutryne per kilogram of dry paint. When samples are taken from wet paint containers, average values of cybutryne are not to be present above 200 mg of cybutryne per kilogram of dry paint.

1.3.3 For ships applying for issuance of anti-fouling system certificates, the implementation dates for control requirements specified in 1.3.1 and 1.3.2 above are to comply with the requirements of the AFS Convention or the requirements of the Administration of the flag State (if any).

1.3.4 The manufacturer of the anti-fouling system is to hold a works approval certificate issued by ISC or equivalent certificate and to provide a proof from the manufacturer.

## 1.4 Class notation

1.4.1 For assignment of the “AFS/AFS+” class notations of environmental protection sub-element for green eco-ships, the survey is to be carried out in accordance with Chapter 2 of the Guidelines upon owner’s request, to confirm compliance with the relevant requirements for anti-fouling systems in 3.5.1, Chapter 3 of ISC Rules for Green Eco-ships.

---

① The molecular formula of cybutryne is C<sub>11</sub>H<sub>19</sub>N<sub>5</sub>S and cybutryne is also called “Irgarol 1051” in market.

② It could be expected that the distribution of the remaining anti-fouling paint on the hull surface is not uniform. Due to hull design and consequent action of the sea water during the service life of the paint, the paint may not have uniformly eroded, some parts in the hull may still have some paint, other parts may not have any paint left. Therefore, the brief samples taken from the hull surface should be representative of the anti-fouling system applied. Average values of cybutryne should not be present above 1,000 mg of cybutryne per kilogram of dry paint. Below this level any remaining cybutryne is expected not to create a negative impact to the marine environment.

## CHAPTER 2 SURVEY OF SHIPS

### 2.1 General requirements

2.1.1 The survey of anti-fouling systems consists of initial survey and additional survey. The survey is to be such as to confirm that the ship's anti-fouling system fully complies with relevant specified requirements.

2.1.2 Survey for the issue of anti-fouling system certificate only applies to ships of 400 GT and above engaged in international voyages, excluding fixed or floating platforms, floating storage units (FSUs), floating production storage and off-loading facilities (FPSOs).

2.1.3 Ships of 24 m or more in length, but less than 400 GT engaged in international voyages (excluding fixed or floating platforms, FSUs and FPSOs) are to carry an AFS Declaration signed by the owner or owner's authorized agent to demonstrate compliance with relevant specified requirements. For ships to which AFS Convention applies, the form in Appendix 2 of Annex 4 of AFS Convention is to be taken for the AFS Declaration. For EU members not accepting the AFS Convention, the form in Annex 3 of REGULATION (EC) No.782/2003 of the European Union is to be taken.

2.1.4 All ships, including the fixed or floating platforms, floating storage units (FSUs), floating production storage and off-loading facilities (FPSOs) which are not applicable as specified in 2.1.2 and 2.1.3, are to be assigned "AFS/AFS+" class notations of environmental protection sub-elements for green eco-ships after satisfactory survey according to this Chapter and in compliance with the relevant requirements of 1.4.1.

2.1.5 Ships affected by Annex 1 of Amendments to AFS Convention as set out in resolution MEPC.331(76) (ships bearing an anti-fouling system that contains cybutryne as biocides in the external coating layer of their hulls or external parts or surfaces on 1 January 2023) are to apply for survey in time and hold a new model form of the International Anti-fouling System Certificate required by Annex 4 of Amendments to AFS Convention within 24 months after 1 January 2023. The survey is to be carried out in accordance with 2.2 and 2.2.3(3) of this Chapter.

2.1.6 For ships not affected by Annex 1 of Amendments to AFS Convention as set out in resolution MEPC.331(76) (including ships on which an anti-fouling system containing cybutryne has been applied previously, but has been covered with a new anti-fouling system complying with Annex 1 of Amendments to AFS Convention prior to 1 January 2023), a new model form of the International Anti-fouling System Certificate required by Annex 4 of Amendments to AFS Convention may be issued during request for next survey. For renewal of certificates for ships mentioned in 2.1.5 and 2.1.6, requirements of the Administrations of flag states are also to be considered (if any).

### 2.2 Request for survey

2.2.1 A Service Notification is to be submitted to ISC by the applicant along with the following information:

(1) Particulars of ship:

- ① name of ship;

- ② distinctive number or letters;
  - ③ port of registry;
  - ④ gross tonnage;
  - ⑤ IMO number.
- (2) A declaration from the anti-fouling system manufacturer with regard to anti-fouling system containing no organotin compounds and/or cybutryne, including:
- ① type (e.g. “organotin-free self polishing type” , “organotin-free ablativ type” , “organotin-free conventional” , “biocide-free silicon type paint, others” . In the case of an anti-fouling system containing no active ingredients, the words “biocide-free” are to be used.), name and colour of anti-fouling system;
  - ② name of anti-fouling system manufacturer;
  - ③ active ingredient(s) and their Chemical Abstract Service Registry Number (CAS number(s));
  - ④ works approval certificate.
- (3) Proof of purchase of the anti-fouling system and/or sealer coat containing no organotin compounds and/or cybutryne.
- (4) Coating application procedure, including procedures for removal of existing coating as appropriate.
- (5) Relevant information of the sealer coat, e.g. name, type and colour if it has been applied.
- (6) Material Safety Data Sheets (MSDSs) of the anti-fouling systems or similar documentation.

## **2.3 Initial surveys**

### 2.3.1 Initial surveys for new buildings

- (1) The following items are to be verified during the survey:
- ① confirming that the documentation contained in 2.2.1 submitted with the request for survey by the applicant is identical to that given in relevant specified requirements and the request for survey;
  - ② confirming that the anti-fouling system applied to the ship is furnished with a valid works approval certificate or equivalent certificate issued by ISC;
  - ③ confirming that the product identification on anti-fouling system containers or packages used during the application process is identical to the system specified in the request for survey;
  - ④ confirming that the coating process of the anti-fouling system, including the anti-fouling system applied to the ship, complies with relevant specified requirements.

(2) Where supporting information from the anti-fouling system manufacturer is not available or does not provide sufficient information, or deemed necessary by the surveyor, sampling and testing or other checks are to be carried out either before, during, or after the anti-fouling system has been applied, in order to verify compliance. See Annex 1 of the Guidelines for sampling methods. No sampling or testing is to affect the integrity, structure or operation of the anti-fouling system.

### 2.3.2 Initial surveys of existing ships

(1) The anti-fouling system not complying with relevant requirements as specified in 1.3.1(2) ① and 1.3.2(2) on existing ships is to be removed and the anti-fouling system is to comply with relevant specified requirements. The removal of anti-fouling systems not complying with relevant specified requirements is to be confirmed by the surveyor and the new anti-fouling system is to be surveyed in accordance with requirements given in 2.3.1 of this Chapter. Or,

(2) If a sealer coat has been applied to the anti-fouling system not complying with relevant requirements as specified in 1.3.1(2) ② and 1.3.2(2), a verification is to be carried out to confirm that the name, type and colour of the sealer coat applied to the ship match those specified in the Service Notification, and that the existing anti-fouling system has been fully covered with that sealer coat. The new anti-fouling system is to be surveyed in accordance with requirements given in 2.3.1 of this Chapter. Or,

(3) For ships requesting only the issue of anti-fouling system certificate, if the existing anti-fouling system on ship is declared to contain no organotin compounds and/or cybutryne in the request for survey by the applicant, compliance with relevant specified requirements is to be confirmed for the anti-fouling system by one or more of the following means of verification:

- ① Reliable documentation, including:
  - a. Material Safety Data Sheets (MSDS), or similar;
  - b. a declaration of compliance from the anti-fouling system manufacturer; and
  - c. invoices from the shipyard and/or the anti-fouling system manufacturer.
- ② Certificates or Statement of Compliance issued by other IACS members or the previous flag State of the ship.
- ③ Sampling and/or testing, where necessary, may be carried out in accordance with Annex 1 of the Guidelines.

### 2.3.3 Confirmation requirements for ships of 24 m and above in length but less than 400 GT engaged in international voyages

(1) It is to be confirmed that the ship carries an AFS Declaration signed by the owner or owner's authorized agent before the ship is put into service for the first time. These declarations are to be accompanied by appropriate documentation (such as a paint receipt or a contractor invoice) or contain an appropriate endorsement. Where it is confirmed to be satisfactory, the corresponding survey checklist is to be filled in and no certificate or statement of compliance is required.

## 2.4 Additional surveys

2.4.1 Additional surveys are to be carried out in any of the following cases of AFS after the initial survey carried out by ISC:

- (1) where the anti-fouling system of a ship is changed or replaced entirely;
- (2) where the scope of repairs affects 25% and more of the anti-fouling system;
- (3) where a ship undergoes a major conversion affecting the anti-fouling system, e.g. adding a hull midsection.

2.4.2 Additional surveys related to 2.4.1(1) and (2) are to be carried out in accordance with the requirements of 2.3.2. However, only the anti-fouling systems which are changed or replaced in the repaired parts are to be surveyed.

2.4.3 Additional surveys of parts of major conversion related to 2.4.1(3) may be regarded as newbuildings subject to determination by ISC, and are to be carried out in accordance with the requirements of 2.3.1.

2.4.4 Confirmation requirements for ships of 24 m and above in length but less than 400 GT engaged in international voyages

(1) Where the anti-fouling system of a ship is changed or replaced or the scope of repairs affects more than 25% of the anti-fouling system, it is to be confirmed that the ship carries an AFS Declaration signed by the owner or owner's authorized agent before the ship is put in the first service. These declarations are to be accompanied by appropriate documentation (such as a paint receipt or a contractor invoice) or contain an appropriate endorsement.

(2) Where it is confirmed to be satisfactory, the corresponding survey checklist is to be filled in and no certificate or statement of compliance is required.

## **CHAPTER 3 ANTI-FOULING SYSTEM CERTIFICATE**

### **3.1 Issuance and endorsement of certificate**

3.1.1 The International Anti-Fouling System Certificate or Statement of Compliance of Anti-Fouling Systems along with the Record Book of Anti-Fouling Systems will be issued to ships by ISC, when authorized by the Administration of the flag State or upon the owner's request, after satisfactory initial surveys in accordance with the Guidelines and complying with the requirements of the AFS Convention.

3.1.2 The Endorsement of Record Book of Anti-Fouling Systems is to be issued to ships upon satisfactory completion of additional surveys, indicating the details of the changed or replaced anti-fouling system. Where a sealer coat has been applied for the existing anti-fouling system on ship and a new anti-fouling system complying with relevant specified requirements is applied after removal of the existing one, the International Anti-Fouling System Certificate or Statement of Compliance of Anti-Fouling Systems along with the Record Book of Anti-Fouling Systems are to be re-issued.

3.1.3 The International Anti-Fouling System Certificate or Statement of Compliance of Anti-Fouling Systems along with the Record Book of Anti-Fouling Systems are to be re-issued to ships holding an International Anti-Fouling System Certificate or Statement of Compliance of Anti-Fouling Systems, upon completion of survey of transfer of flag by ISC.

### **3.2 Expiry and revalidation of certificate**

3.2.1 When the anti-fouling system of a ship is changed or replaced, or when the scope of repairs affects 25% and more of the anti-fouling system, or when a ship undergoes a major conversion and the additional survey is not carried out, the International Anti-Fouling System Certificate or Statement of Compliance of Anti-Fouling Systems along with the Record Book of Anti-Fouling Systems will automatically cease to be valid.

3.2.2 Upon transfer of the ship to the flag of another State, the existing International Anti-Fouling System Certificate or Statement of Compliance of Anti-Fouling Systems along with the Record Book of Anti-Fouling Systems will automatically cease to be valid.

3.2.3 Where the ship's certificate ceases to be valid, the survey when applying for revalidation of the certificate is to be carried out in accordance with 2.3.2(3) of the Guidelines.

## **ANNEX 1 METHODS FOR SAMPLING AND ANALYSIS OF ANTI-FOULING SYSTEMS**

### **1 Purpose**

1.1 The Guidelines are intended to stipulate methods for sampling and analysis of anti-fouling systems on ships in order to verify compliance with relevant specified requirements.

1.2 Method 1 specified in the Guidelines applies to anti-fouling systems other than silicon-based anti-fouling systems on ships.

### **2 Definitions**

2.1 “Threshold value” means the content limit of the chemical under investigation below which compliance with the relevant provisions of the AFS Convention may be assumed.

2.2 “Tolerance range” means the numerical range added to the threshold value indicating the range where detected contents above the threshold value are acceptable due to recognised analytical inaccuracy and thus do not compromise the assumption of compliance specified in the International Convention on the Control of Harmful Anti-Fouling Systems on Ships, 2001.

### **3 Precautions and secure means**

3.1 The material safety data sheet (MSDS) for the solvent or paint is to be made available to persons carrying out sampling and read by them. Appropriate precautions are to be taken, e.g. wearing long sleeve gloves of nitrile rubber.

3.2 Persons carrying out sampling are to be provided with the following safeguards:

- (1) safe access to reach the hull, e.g. scaffolding or platforms, crane baskets, cherry-pickers, gangways;
- (2) means of preventing falling from high altitude, e.g. railings, a climbing harness, a safety line;
- (3) a lifejacket.

3.3 Access to ships is to be made by secure means. Scaffolding is to be securely constructed and cherry-pickers or dock-arms are to be properly constructed and maintained if they are to be used to gain access. There is to be a system to record the presence of the inspector in the dock area, and he is preferably to be accompanied. Safety harnesses is to be worn in cherry-picker baskets, if used.

### **4 General requirements for sampling**

4.1 Specimens of paint for analysis during survey and certification can be taken either as wet paint from product containers, or dry paint film sampled from the hull.

4.2 Wet paint samples are to be taken in accordance with the following requirements:

- (1) wet paint samples are to be taken from a newly opened container and paint is to be stirred to ensure even consistency before sampling;
- (2) the equipment used for sampling is to be clean;
- (3) liquid paint samples are to be stored in appropriate sealed packaging which will not react with or contaminate the sample;
- (4) in the case of multi-component coatings (where on-site mixing of several components is required prior to application), samples of each component are to be taken and the required mixing ratio recorded;
- (5) when a sample of wet paint is taken from a container, details of the paint are to be recorded, e.g. details required for the International Anti-Fouling System Certificate along with a batch number for the product.

4.3 When samples are directly taken from the hull, the following requirements are to be complied with:

- (1) the integrity or operation of the anti-fouling system is not to be affected;
- (2) sampling where the anti-fouling coating is visibly damaged or on block mark areas on the flat bottom of the ship is to be avoided. Sampling adjacent to or below areas where the anti-fouling system is damaged is also to be avoided;
- (3) when a sample point on the hull has been selected, any fouling present is to be removed with water and a soft sponge/cloth before taking a specimen of the anti-fouling system to avoid contamination of sample. Where possible, if carried out in dry-dock, sampling is to be carried out after the hull has been water-washed;
- (4) persons conducting sampling are to receive appropriate training to be familiar with sampling procedures and methods;
- (5) the sampling method is to take into account the type of anti-fouling system used on the ship.

## **5 Number of samples**

5.1 Each sample is to allow for a retention quantity for back-up in the event of a dispute. For dry samples, triplicate specimens of paint at each sampling point are to be taken as close to each other as possible on the hull (e.g. at least within 10 cm of each other but without overlap).

5.2 In cases where it is recognized that more than one type of anti-fouling system is present on the hull, where access can be gained, samples are to be taken from each type of system and the number of sample points is to reflect representative areas of the ship's hull.

## **6 Record sheet for the sampling procedure**

6.1 The results of sampling and analysis are to be fully documented. Refer to the model form in Appendix 1 for the record of Method 1 and refer to the model form in Appendix 2 for the record of Method 2.

## **7 Analysis**

7.1 The analysis of the anti-fouling system is to be conducted by a laboratory recognized by ISC and meeting the ISO 17025 standard.

7.2 For organotin, results of the analysis are to be expressed in unit such as: mg tin (Sn) per kg of dry paint.

7.3 For cybutryne, results of the analysis are to be expressed in unit such as: mg cybutryne per kg of dry paint.

## **8 Sampling method 1**

### **8.1 Sampling device and materials on the hull**

8.1.1 The sampling device is constructed in a way that only the upper layer of paint is removed, thereby and is to leave any underlying paint (sealer, primer etc.) intact. This is achieved through the use of a moving disk, (eccentric rotation) which is covered by an abrasive material like quartz or glass fibre fabric. This abrasive material has to be suitable for its use as a supporting material for the removed paint. For example, a polyethylene disk, on which fibre glass fabric can be mounted by the use of an O-ring, is moved on an eccentrically rotating axis.

8.1.2 The device is to fulfill the following requirements:

- (1) the device has to work independently from any stationary power supply;
- (2) the applied force has to be constant during the operation, and the area for paint removal has to be defined;
- (3) the abrasive material has to be inert against chemical solvents and acids and must not contain more than trace amounts of tin or tin compounds and/or cybutryne;
- (4) the amount of paint removed after a regular operation of the device has to be shown to exceed 20 mg per sample.

### **8.2 Sampling procedure on the hull**

8.2.1 The mass of the fibre glass pads is to be weighed with a precision of at least 1 mg. The weight of the fibre glass pads is to be documented for each sample.

8.2.2 The fabric is to be moistened thoroughly with isopropanol (0.8 ml per sample) immediately before sampling.

8.2.3 When a sample point on the hull has been selected, any fouling present is to be removed with water and a soft sponge/cloth before taking a specimen of the anti-fouling system. Where possible, if carried out in dry-dock, sampling is to be carried out after the hull has been water-washed.

8.2.4 The sampling device is then held against the surface to be sampled for a period of 5 seconds, prior to the sampling device (see Figure 1) being switched on.

8.2.5 The sampling device is switched on, thereby removing paint by the circular motion of the fibre glass fabric against the surface of the ship.

8.2.6 The sampling device is to be applied to the surface of the hull for a suitable period of time, such that at least 20 mg of paint is taken up by the pad. As a general rule, if the pad colour after sampling matches the colour of the hull coating a sufficient sample has been taken.

8.2.7 The specimens are to be taken as close to each other as possible, but without overlap.

8.2.8 Upon completion of the sampling, the fibre glass fabric pads are to be left to dry, and re-weighed.

8.2.9 The number of samples will differ depending on the substances targeted.

(1) Case A. Analysis of organotin only. Every sample is to be taken in triplicate;

Specimen 'A' – for step 1

Specimen 'B' – for step 2

Specimen 'X' – for storage/back up

(2) Case B. Analysis of cybutryne only. Every sample is to be taken in duplicate;

Specimen 'C' – for a one-step analysis

Specimen 'X' – for storage/back up

(3) Case C. Simplified approach to detect organotin and cybutryne. Every sample is to be taken in duplicate;

Specimen 'C' – for a one-step analysis

Specimen 'X' – for storage/back up

8.2.10 Samples are to be stored in appropriate sealed packaging, which will not react with or contaminate the sample.

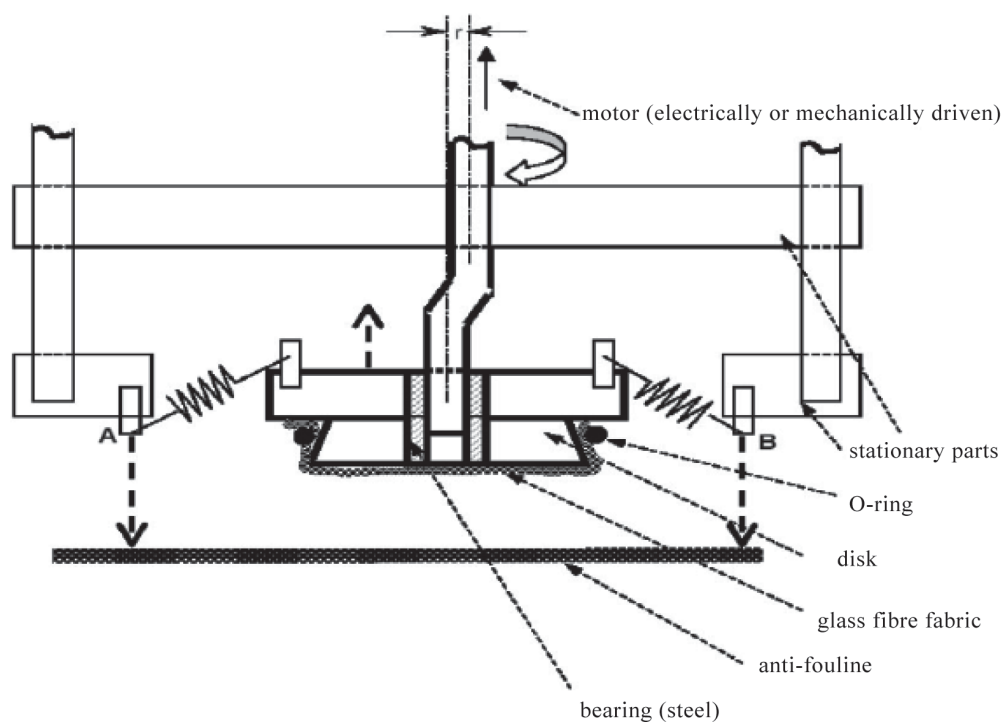

**Figure 1 Schematic cross section of the sampling device**

The indicated points A and B are to be pressed against the surface. The polyethylene disk, covered with the glass fibre fabric, is moved with an amplitude of  $2r$  ( $r = 1.0$  cm) on the surface.

Specific data:

Force applied on the paint surface:	25 N (Newton)
Effective diameter of the disk:	50 mm
Frequency of rotation:	6 rotations/s
Solvent used:	isopropanol (0.8 ml per sample)

### 8.3 Analytical procedure

#### Case A. Analysis of organotin only

8.3.1 The identification of anti-fouling systems containing organotin is based on a two-step analysis. The first step analyzes Specimen 'A' for the presence of total tin; the second step, detecting specific organotin compounds, is only necessary in the case of Specimen 'A' producing positive result.

8.3.2 Specimen 'A' is analysed for mass of total tin per kilogram of dry paint or mass of tin per sample by applying inductively coupled plasma/mass spectrometry (ICP/MS), once the material has been solubilized by digestion using aqua regia. Any other scientifically recognized procedure for tin analysis (such as AAS, XRF and ICP-OES) is acceptable.

8.3.3 Where Specimen 'A' produces positive results, the second step is to be carried out. Specimen 'B' is analysed using the following procedure and specific organotin compounds are to be identified and quantified:

- (1) solvent extraction as supported by sonication in an ultrasonic bath;
- (2) derivatisation with ethylmagnesium bromide;
- (3) clean-up of the extract;
- (4) analysis using high resolution gas chromatography/mass spectrophotometry (GC/MS);
- (5) quantifications using tripropyltin as a standard.

8.3.4 Other equally reliable method for the chemical identification and quantification of organotin compounds is acceptable.

Case B. Analysis of cybutryne only

8.3.5 A one-step analysis of Specimen 'C' for determining the amount of cybutryne, using gas chromatography/mass spectrophotometry (GC/MS).

8.3.6 Specimen 'C' is to be analyzed using the following procedure:

- (1) sample extraction using ethyl acetate with added internal standard (ametryn) using an ultrasonic bath for 15 minutes;
- (2) centrifugation of the samples at 6000 rcf for 5 minutes;
- (3) analysis of the supernatant using high resolution capillary GC/MS, with the MS operating in SIM mode;
- (4) quantification using reference cybutryne solutions and an internal standard normalization procedure; and
- (5) modified GC/MS methods resulting in an expanded measurement uncertainty ( $k=2$ ; 95% confidence) of 25% are acceptable.

8.3.7 Other methods for the chemical identification and quantification of cybutryne, if proven equally reliable, could be accepted.

Case C. Simplified approach to detect organotin and cybutryne

8.3.8 A one-step analysis of Specimen 'C' for determining the amount of organotin and cybutryne using gas chromatography/mass spectrophotometry (GC/MS).

- (1) sample extraction using toluene with added internal standard (ametryn) using an ultrasonic bath for 15 minutes;
- (2) derivatization with ethylmagnesium bromide;
- (3) clean-up of the extract;
- (4) centrifugation of the samples at 6000 rcf for 5 minutes;
- (5) analysis of the supernatant using high resolution capillary GC/MS, with the MS operating in SIM mode;
- (6) cybutryne quantification using reference cybutryne solutions and an internal standard normalization procedure. Organotin quantification using tripropyltin as the internal standard; and
- (7) modified GC/MS methods resulting in an expanded measurement uncertainty ( $k=2$ ; 95% confidence) of 25% are acceptable.

#### 8.4 Threshold value and tolerance range for the analytical method

##### Case A. Analysis of organotin only

8.4.1 The threshold value for the method is “2,500 mg tin (Sn) per kg of dry paint”.

8.4.2 The tolerance range is 20% above the threshold value, i.e. 500 mg Sn/kg of dry paint in addition to the threshold value.

8.4.3 Small quantities of organotin compounds, acting as chemical catalysts are allowed, provided they are not acting as a biocide. When used a catalyst, an organotin compound is not to be present above 2,500 mg total tin per kg of dry paint.

##### Case B. Analysis of cybutryne only

8.4.4 The threshold value for the method is “1,000 mg of cybutryne per kg of dry paint”.

8.4.5 The tolerance range is 25% above the threshold value, i.e. 250 mg cybutryne/kg of dry paint in addition to the threshold value.

#### 8.5 Definition of compliance

##### Case A. Analysis of organotin only

8.5.1 The analytical verification of compliance is performed in a two-step procedure according to Figure 2 below.

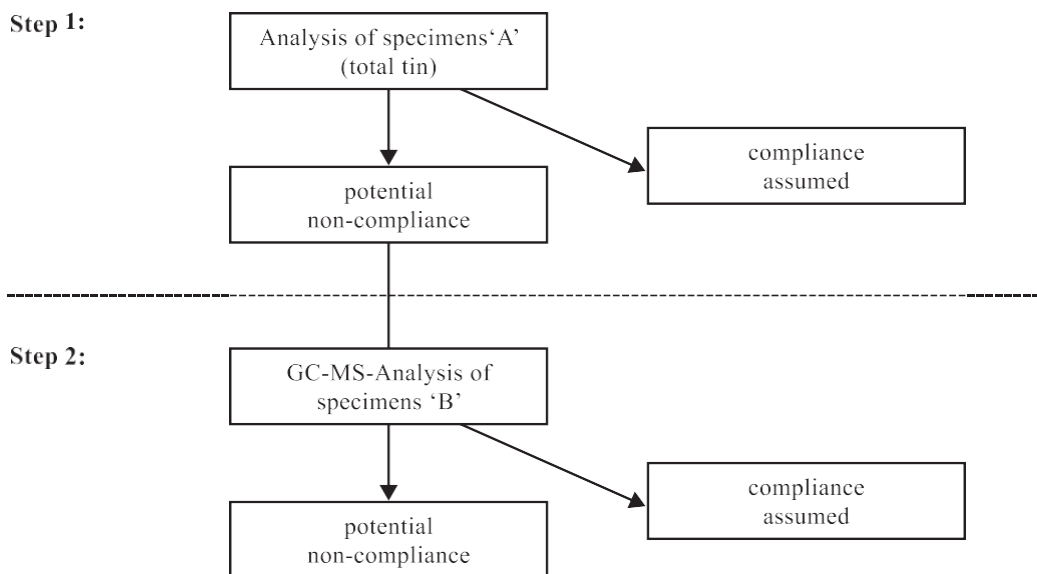

**Figure 2 Flow diagram illustrating the two-step analytical procedure for organotin compounds**

8.5.2 Compliance with the specified requirements is assumed when the results from the specimen 'A', analysed in step 1, meet the following (unless expressly provided otherwise), and then performing step 2 is not necessary:

- (1) no more than 25% of the total number of samples yield results above 2,500 mg total tin per kilogram dry paint; and
- (2) no sample of the total number of samples shows a concentration of total tin higher than the sum of threshold value plus the tolerance range, i.e. no sample must exceed the concentration 3,000 mg Sn/kg of dry paint.

8.5.3 Where Specimen 'A' produces analytical result not complying with 8.5.2, Specimen 'B' is to be analyzed in accordance with 8.3.3.

8.5.4 Compliance with the specified requirements is assumed when the results from the specimens 'B', analysed in step 2, meet the requirements contained in 8.5.2 at the same time (unless expressly provided otherwise). Non-compliance with the specified requirements is indicated if the requirements contained in 8.5.2 are not met. Such results are to be interpreted to mean that organotin compounds acting as a biocide are present in the anti-fouling system.

Case B. Analysis of cybutryne only

8.5.5 Compliance with relevant specified requirements is assumed when the results from specimen 'C', analysed in a one-step analysis, meet the following requirement:

- (1) The average value of the total number of specimens shows a concentration below the threshold plus the tolerance range, i.e. 1,250 mg of cybutryne per kg of dry paint.

8.5.6 Non-compliance with relevant specified requirements is assumed when the results from specimen 'C', analysed in a one-step analysis, meet the following requirement:

(1) An average value of the total number of specimens shows a concentration above the threshold plus the tolerance range, i.e. 1,250 mg of cybutryne per kg of dry paint.

#### Case C. Simplified approach to detect organotin and cybutryne

8.5.7 Compliance with relevant specified requirements is assumed when the results from specimen 'C', analysed in a one-step analysis, meet the two conditions below:

(1) for organotin, the average value of the total number of specimens shows a concentration below the threshold plus the tolerance range, i.e. 3,000 mg Sn/kg of dry paint; and

(2) for cybutryne, the average value of the total number of specimens shows a concentration below the threshold plus the tolerance range, i.e. 1,250 mg of cybutryne per kg of dry paint.

8.5.8 Non-compliance with relevant specified requirements is assumed when the results from specimen 'C', analysed in a one-step analysis, meet the following requirement:

(1) If one of the conditions set out in paragraph 8.5.7 above is not met, this indicates non-compliance. Such results should be interpreted to mean that cybutryne or organotin is present in the anti-fouling system at a level at which it would act as a biocide.

## **9 Sampling method 2**

### 9.1 Sampling device and materials

9.1.1 The sampling is carried out by using abrasive paper rubbing on the surface of the anti-fouling system. Abrasive paper is pasted on a disc of approximately 10 mm in diameter. Rubbing the surface of the anti-fouling system with the disc collects several milligrams of the sample on to the abrasive paper.

9.1.2 Rubbing the thin area, less than several micrometer in depth from the surface of the anti-fouling system, avoids affecting the coatings lying underneath such as sealers.

9.1.3 The sampling device consists of an electric motor, two (or three) rotating rods on each of which a disc is attached, and a battery for electric power supply. The discs are pressed on to the surface of ship's hull by spring coils. The disks rotate counter-clockwise while the rods turn clockwise around the centre of the device. See Figure 3.

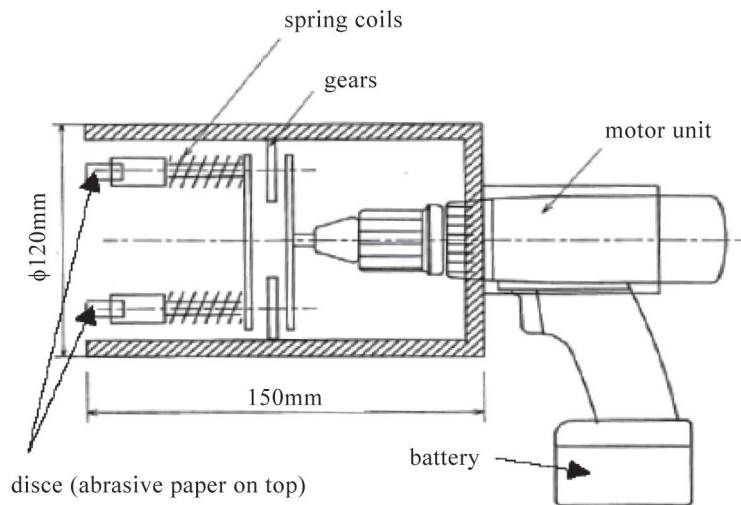

**Figure 3 Schematic diagram of sampling device**

9.1.4 Sampling point is selected such that the anti-fouling system is intact over an area of approximately 50 cm × 50 cm or more.

9.1.5 Depending on the substances targeted as listed in Annex 1 of the AFS Convention:

- (1) Case A. For the analysis of organotin only, at each sampling point, three sets of sampling, or more if necessary, are to be carried out to obtain at least six specimens.
- (2) Case B. For the analysis of cybutryne only, at each sampling point, three sets of sampling, or more if necessary, are to be carried out to obtain at least six specimens.
- (3) Case C. For the analysis of organotin and cybutryne, at each sampling point, three sets of sampling, or more if necessary, are to be carried out to obtain at least six specimens.

9.1.6 The device is pressed on the ship's hull where it is appropriate to be sampled and held by hand. The electric motor is switched on to slide along the painted surface to lightly scrape off the fragments of the paint onto the abrasive paper. After the sample collection, each disc is removed from the device and stored in an inert container.

9.1.7 Sampling is normally to be carried out with the sampling device. However, in the case that accessibility to the sampling point is poor, it is acceptable to collect samples with the discs by hand.

Case A. Analysis of organotin only

## 9.2 The first-stage analysis

9.2.1 The first-stage analysis may be carried out on the spot of the survey, e.g. dry docks and sea ports. In order to accomplish the on-site analysis, X-ray fluorescence analysis (XRF) method may be used to detect total tin content.

9.2.2 Among several types of the XRF instruments, an energy-dispersive spectrometer with a silicon drift detector (SDD), which is compact in size and be able to be operated without liquid nitrogen, is preferable to the present analytical system for a field use, whereas wave-length dispersion system or solid-state detector are also available if the analysis carried out at laboratories.

9.2.3 The Surveyor may use software for the tin analysis to detect total tin in the specimens. Where analysis is carried out with software, the software may in advance need a calibration curve of the characteristic X-ray intensity of tin in relation to the tin content particularly in the range of 0.1 to 0.5%.

9.2.4 After the warming-up of the XRF instrument and starting-up of the computer, a specimen is placed on the sample stage of the instrument. Analysis may be executed by the customized software. A single batch of analysis for one specimen normally takes 5 minutes and the result is shown on a display automatically.

9.2.5 Since the XRF analysis does not affect any properties of the specimens, all of the collected specimens (six to nine specimens), including those for the second analysis and storage, are able to be used for this analysis.

9.2.6 Interpretation of the result at the first-stage analysis

(1) Following the procedures above, XRF data of six, or nine, specimens are obtained for each sampling point. Omitting the maximum and minimum values from the data, an average of the tin content is calculated from the intermediate values for the representing value of the sampling point.

(2) Compliance with relevant specified requirements is assumed when the tin contents (average values) from the samples do not exceed the sum of the threshold value (2,500 mg per kg) and a tolerance range (500 mg per kg) (unless expressly provided otherwise).

(3) When one or more average values of samples from different sampling points do not meet the above criteria, the samples are to be sent to a laboratory for the second stage analysis.

9.3 The second-stage analysis

9.3.1 Since the second-stage analysis provides the final and definitive results of the samples, the method is to be thoroughly reviewed by experts based on scientific evidence.

9.3.2 The collected paint specimens are removed from the abrasive paper and total mass is measured with an electronic balance to an order of 0.1 mg. The specimens are hydrolysed with sodium hydroxide aqueous solution, extracted with organic solvent, and then derivatised with propylmagnesium bromide. After cleaning up the extract, analysis using high resolution gas chromatography/mass spectrometry (GC/MS) is carried out. For quantification analysis, tetrabutyl tin d36 is added as the internal standard.

9.3.3 These analyses provide the data of chemical species and their content. The content of organotin is expressed as mass of tin (mg) per kg of dry paint.

Case B. For the analysis of cybutryne only

9.4 The collected paint specimens are removed from the abrasive paper and total mass is measured with an electronic balance to an order of 0.1 mg. The following procedure is proposed for determining the concentration of cybutryne:

- (1) sample extraction using ethyl acetate with added internal standard (ametryn) using an ultrasonic bath for 15 minutes;
- (2) centrifugation of the samples at 6000 rcf for 5 minutes;
- (3) analysis of the supernatant using high resolution capillary GC/MS, with the MS operating in SIM mode;
- (4) quantification using reference cybutryne solutions and an internal standard normalization procedure; and
- (5) modified GC/MS methods resulting in an expanded measurement uncertainty ( $k=2$ ; 95% confidence) of 25% are acceptable.

Case C. Simplified approach to detect organotin and cybutryne

9.5 The collected paint specimens are removed from the abrasive paper and total mass is measured with an electronic balance to an order of 0.1 mg. The following procedure is proposed for determining the concentration of organotin and cybutryne:

- (1) sample extraction using toluene with added internal standard (ametryn) using an ultrasonic bath for 15 minutes;
- (2) addition of sodium hydroxide aqueous solution to hydrolyse the sample and to facilitate the extraction to the toluene;
- (3) centrifugation of the samples at 6000 rcf for 5 minutes;
- (4) collection of the supernatant and derivatization with propylmagnesium bromide;
- (5) clean-up of the extract;
- (6) analysis of the toluene solution using high resolution capillary GC/MS, with the MS operating in SIM mode;
- (7) cybutryne quantification using reference cybutryne solutions and an internal standard normalization procedure; organotin quantification using tetrabutyl tin d36 is added as the internal standard; and
- (8) modified GC/MS methods resulting in an expanded measurement uncertainty ( $k=2$ ; 95% confidence) of 25% are acceptable.

9.6 Definition of compliance

Case A. Analysis of organotin only

9.6.1 Compliance with the specified requirements is assumed when the results from the second-stage analysis meet the following requirements at the same time (unless expressly provided otherwise):

(1) no more than 25% of the total number of samples yield results above 2,500 mg total tin per kilogram dry paint; and

(2) no sample of the total number of samples shows a concentration of total tin higher than the sum of threshold value plus the tolerance range, i.e. no sample must exceed the concentration 3,000 mg Sn/kg of dry paint.

9.6.2 When the result does not meet the above criteria in 9.6.1, it is interpreted to mean that organotin compounds are present in the anti-fouling system at a level where they would act as a biocide.

#### Case B. Analysis of cybutryne only

9.6.3 Compliance with relevant specified requirements is assumed when the average value of the total number of specimens shows a concentration below the threshold plus the tolerance range, i.e. 1,250 mg of cybutryne per kg of dry paint.

9.6.4 When the result does not meet the above criterion in 9.6.3, it is interpreted to mean that cybutryne is present in the anti-fouling system at a level where it would act as a biocide. Then, non-compliance with relevant specified requirements is assumed.

#### Case C. Simplified approach to detect organotin and cybutryne

9.6.5 Compliance with relevant specified requirements is assumed when the results from the cybutryne and organotin analysis meet the two conditions below:

(1) for organotin, the average value of the total number of specimens shows a concentration below the threshold plus the tolerance range i.e. 3,000 mg Sn/kg of dry paint; and

(2) for cybutryne, the average value of the total number of specimens shows a concentration below the threshold plus the tolerance range, i.e. 1,250 mg of cybutryne per kg of dry paint.

9.6.6 When the results do not meet one of the conditions above, it is interpreted to mean that organotin compounds or cybutryne are present in the anti-fouling system at a level where they would act as a biocide. Then, non-compliance with relevant specified requirements is assumed.



<b>SECTION 3: Analysis and results</b>							
<b>Case A. Analysis of organotin only</b>							
<b>1. Step 1 total tin analysis:</b>							
Company name:				Date:			
Analyst responsible:							
<b>2. Specimen 'A' results:</b>				Total number of specimens 'A' analysed:			
No.	mg Sn/kg	No.	mg Sn/kg	No.	mg Sn/kg	No.	mg Sn/kg
1		5		9		13	
2		6		10		14	
3		7		11		15	
4		8		12		16	
Number of specimens exceeding 2,500 mg/kg:							
1 or more specimens exceeding 3,000 mg/kg:				<input type="checkbox"/> Yes		<input type="checkbox"/> No	
Conclusion:				Step 2 required		<input type="checkbox"/>	
				Compliance, further analysis unnecessary		<input type="checkbox"/>	
<b>3. Additional comments concerning analysis of results from Specimens 'A':</b>							
<b>4. Organotin analysis undertaken by:</b>							
Company name:				Date:			
Analyst responsible:							
<b>5. Specimen 'B' results:</b>				Total number of specimens 'B' analysed:			
No.	mg Sn/kg	No.	mg Sn/kg	No.	mg Sn/kg	No.	mg Sn/kg
1		5		9		13	
2		6		10		14	
3		7		11		15	
4		8		12		16	
Number of specimens exceeding 2,500 mg/kg:							
1 or more specimens exceeding 3,000 mg/kg:				<input type="checkbox"/> Yes		<input type="checkbox"/> No	
Conclusion:				Non-compliance		<input type="checkbox"/>	
				Compliance, further analysis unnecessary:		<input type="checkbox"/>	
<b>6. Additional comments concerning analysis of results from Specimens 'B':</b>							

<b>Case B. Analysis of cybutryne only</b>	
<b>1. A one-step analysis using gas chromatography/mass spectrophotometry (GC/MS)</b> Company name: _____ Analyst responsible: _____ Date: _____	
<b>2. Specimen 'C' results:</b>	
Total number of specimens 'C' analysed by GC-MS:	_____
Average concentration of cybutryne (mg of cybutryne per kg of dry paint):	_____
<b>3. Conclusions:</b>	
The average concentration of cybutryne exceeds the threshold of 1,250 mg of cybutryne per kg of dry paint <input type="checkbox"/> Yes <input type="checkbox"/> No	
<b>4. Additional comments concerning analysis of results from Specimens 'C':</b>	
<b>Case C. Simplified approach to detect organotin and cybutryne</b>	
<b>1. A one-step analysis using gas chromatography/mass spectrophotometry (GC/MS)</b> Company name: _____ Analyst responsible: _____ Date: _____	
<b>2. Specimen 'C' results:</b>	
Total number of specimens 'C' analysed by GC-MS:	_____
Average concentration of organotin (mg Sn per kg of dry paint):	_____
Average concentration of cybutryne (mg of cybutryne per kg of dry paint):	_____
<b>3. Conclusions:</b>	
The average concentration of organotin exceeds the threshold of 3,000 mg Sn/kg of dry paint <input type="checkbox"/> Yes <input type="checkbox"/> No	
The average concentration of cybutryne exceeds the threshold of 1,250 mg of cybutryne/kg of dry paint <input type="checkbox"/> Yes <input type="checkbox"/> No	
<b>4. Additional comments concerning analysis of results from Specimens 'C':</b>	
<b>SECTION 4: Final conclusion</b>	
<b>Summarized conclusion:</b>	
Compliance with AFS Convention assumed <input type="checkbox"/>	
Non-compliance with AFS Convention assumed <input type="checkbox"/>	

**THIS IS TO CERTIFY that this Record is correct in all respects.**

**Issued at**.....  
(Place of issue of Record)

.....  
(Date of issue) (Printed name and signature of authorized surveyor issuing the Record)

(Seal or stamp of China Classification Society)

**APPENDIX 2 FORM OF RECORD SHEET APPLICABLE TO METHOD 2**

**RECORD SHEET FOR THE SAMPLING AND ANALYSIS OF ANTI-FOULING SYSTEMS ON SHIP HULLS – ORGANOTIN COMPOUNDS AND/OR CYBUTRYNE**

		Record number:
Section 1: Administration		
1. Country		2. Location
3. Date		
4. Reason for survey/inspection		
5. Details of the ship		
5.1 Name of ship		
5.2 Distinctive number or letters		
5.3 Gross tonnage		5.4. Year of build
5.5 Owner or operator of ship		
5.6 Flag State		5.7 Class of ship
5.8 Authority of AFS certificate		
5.9 Date of issue		
5.10 Date of last endorsement		
5.11 IMO number		
5.12 Name of shipmaster		
5.13 Product name of anti-fouling system		
5.14 Name of manufacturer		
5.15 Name of shipyard where applied		
5.16 Comments		
6. Inspecting official's details		
6.1 Name		
6.2 Comments		

**Section 2: Sampling and analysis**

**Case A. Analysis of organotin only**

				Record number		
Sampling and Stage 1 analysis (X-ray fluorescence analysis)						
Date:				Instrument I.D.		
Sample location	Specimen I.D.	Sample disc	Content of tin (mg/ kg)	max	min	Average
A	A1	<input type="checkbox"/> abrasive		<input type="checkbox"/>	<input type="checkbox"/>	Average _____mg/kg
	A2	<input type="checkbox"/> metal		<input type="checkbox"/>	<input type="checkbox"/>	
	A3	<input type="checkbox"/> others		<input type="checkbox"/>	<input type="checkbox"/>	
	A4	<input type="checkbox"/> abrasive		<input type="checkbox"/>	<input type="checkbox"/>	<input type="checkbox"/> >2,500mg/kg
	A5	<input type="checkbox"/> metal		<input type="checkbox"/>	<input type="checkbox"/>	
	A6	<input type="checkbox"/> others		<input type="checkbox"/>	<input type="checkbox"/>	
	A7	<input type="checkbox"/> abrasive		<input type="checkbox"/>	<input type="checkbox"/>	<input type="checkbox"/> >3,000 mg/kg
	A8	<input type="checkbox"/> metal		<input type="checkbox"/>	<input type="checkbox"/>	
	A9	<input type="checkbox"/> others		<input type="checkbox"/>	<input type="checkbox"/>	
B	B1	<input type="checkbox"/> abrasive		<input type="checkbox"/>	<input type="checkbox"/>	Average _____mg/kg
	B2	<input type="checkbox"/> metal		<input type="checkbox"/>	<input type="checkbox"/>	
	B3	<input type="checkbox"/> others		<input type="checkbox"/>	<input type="checkbox"/>	
	B4	<input type="checkbox"/> abrasive		<input type="checkbox"/>	<input type="checkbox"/>	<input type="checkbox"/> >2,500mg/kg
	B5	<input type="checkbox"/> metal		<input type="checkbox"/>	<input type="checkbox"/>	
	B6	<input type="checkbox"/> others		<input type="checkbox"/>	<input type="checkbox"/>	
	B7	<input type="checkbox"/> abrasive		<input type="checkbox"/>	<input type="checkbox"/>	<input type="checkbox"/> >3,000 mg/kg
	B8	<input type="checkbox"/> metal		<input type="checkbox"/>	<input type="checkbox"/>	
	B9	<input type="checkbox"/> others		<input type="checkbox"/>	<input type="checkbox"/>	
C	C1	<input type="checkbox"/> abrasive		<input type="checkbox"/>	<input type="checkbox"/>	Average _____mg/kg
	C2	<input type="checkbox"/> metal		<input type="checkbox"/>	<input type="checkbox"/>	
	C3	<input type="checkbox"/> others		<input type="checkbox"/>	<input type="checkbox"/>	
	C4	<input type="checkbox"/> abrasive		<input type="checkbox"/>	<input type="checkbox"/>	<input type="checkbox"/> >2,500mg/kg
	C5	<input type="checkbox"/> metal		<input type="checkbox"/>	<input type="checkbox"/>	
	C6	<input type="checkbox"/> others		<input type="checkbox"/>	<input type="checkbox"/>	
	C7	<input type="checkbox"/> abrasive		<input type="checkbox"/>	<input type="checkbox"/>	<input type="checkbox"/> >3,000 mg/kg
	C8	<input type="checkbox"/> metal		<input type="checkbox"/>	<input type="checkbox"/>	
	C9	<input type="checkbox"/> others		<input type="checkbox"/>	<input type="checkbox"/>	
D	D1	<input type="checkbox"/> abrasive		<input type="checkbox"/>	<input type="checkbox"/>	Average _____mg/kg
	D2	<input type="checkbox"/> metal		<input type="checkbox"/>	<input type="checkbox"/>	
	D3	<input type="checkbox"/> others		<input type="checkbox"/>	<input type="checkbox"/>	
	D4	<input type="checkbox"/> abrasive		<input type="checkbox"/>	<input type="checkbox"/>	<input type="checkbox"/> >2,500mg/kg
	D5	<input type="checkbox"/> metal		<input type="checkbox"/>	<input type="checkbox"/>	
	D6	<input type="checkbox"/> others		<input type="checkbox"/>	<input type="checkbox"/>	
	D7	<input type="checkbox"/> abrasive		<input type="checkbox"/>	<input type="checkbox"/>	<input type="checkbox"/> >3,000 mg/kg
	D8	<input type="checkbox"/> metal		<input type="checkbox"/>	<input type="checkbox"/>	
	D9	<input type="checkbox"/> others		<input type="checkbox"/>	<input type="checkbox"/>	



	A4	<input type="checkbox"/> abrasive		
	A5	<input type="checkbox"/> metal		
	A6	<input type="checkbox"/> others		
	A7	<input type="checkbox"/> abrasive		
	A8	<input type="checkbox"/> metal		
	A9	<input type="checkbox"/> others		
B	B1	<input type="checkbox"/> abrasive		
	B2	<input type="checkbox"/> metal		
	B3	<input type="checkbox"/> others		
	B4	<input type="checkbox"/> abrasive		
	B5	<input type="checkbox"/> metal		
	B6	<input type="checkbox"/> others		
	B7	<input type="checkbox"/> abrasive		
	B8	<input type="checkbox"/> metal		
	B9	<input type="checkbox"/> others		
C	C1	<input type="checkbox"/> abrasive		
	C2	<input type="checkbox"/> metal		
	C3	<input type="checkbox"/> others		
	C4	<input type="checkbox"/> abrasive		
	C5	<input type="checkbox"/> metal		
	C6	<input type="checkbox"/> others		
	C7	<input type="checkbox"/> abrasive		
	C8	<input type="checkbox"/> metal		
	C9	<input type="checkbox"/> others		
D	D1	<input type="checkbox"/> abrasive		
	D2	<input type="checkbox"/> metal		
	D3	<input type="checkbox"/> others		
	D4	<input type="checkbox"/> abrasive		
	D5	<input type="checkbox"/> metal		
	D6	<input type="checkbox"/> others		
	D7	<input type="checkbox"/> abrasive		
	D8	<input type="checkbox"/> metal		
	D9	<input type="checkbox"/> others		
Average concentration of cybutryne (mg of cybutryne per kg of dry paint)				
Sampled by			Analysed by	
Signature			Signature	

**Case C. Simplified approach to detect organotin and cybutryne**

				Record number
Sampling and gas chromatography/mass spectrometry analysis				
Date:			Instrument I.D.	
Sample location	Specimen I.D.	Sample disc	Comments on the samples and sampling procedure	Comments on the sample location
A	A1	<input type="checkbox"/> abrasive		
	A2	<input type="checkbox"/> metal		
	A3	<input type="checkbox"/> others		
	A4	<input type="checkbox"/> abrasive		
	A5	<input type="checkbox"/> metal		
	A6	<input type="checkbox"/> others		
	A7	<input type="checkbox"/> abrasive		
	A8	<input type="checkbox"/> metal		
	A9	<input type="checkbox"/> others		
B	B1	<input type="checkbox"/> abrasive		
	B2	<input type="checkbox"/> metal		
	B3	<input type="checkbox"/> others		
	B4	<input type="checkbox"/> abrasive		
	B5	<input type="checkbox"/> metal		
	B6	<input type="checkbox"/> others		
	B7	<input type="checkbox"/> abrasive		
	B8	<input type="checkbox"/> metal		
	B9	<input type="checkbox"/> others		
C	C1	<input type="checkbox"/> abrasive		
	C2	<input type="checkbox"/> metal		
	C3	<input type="checkbox"/> others		
	C4	<input type="checkbox"/> abrasive		
	C5	<input type="checkbox"/> metal		
	C6	<input type="checkbox"/> others		
	C7	<input type="checkbox"/> abrasive		
	C8	<input type="checkbox"/> metal		
	C9	<input type="checkbox"/> others		
D	D1	<input type="checkbox"/> abrasive		
	D2	<input type="checkbox"/> metal		
	D3	<input type="checkbox"/> others		
	D4	<input type="checkbox"/> abrasive		
	D5	<input type="checkbox"/> metal		
	D6	<input type="checkbox"/> others		
	D7	<input type="checkbox"/> abrasive		
	D8	<input type="checkbox"/> metal		
	D9	<input type="checkbox"/> others		

Average content of organotin (mg of organotin per kg of dry paint)		
Average concentration of cybutryne (mg of cybutryne per kg of dry paint)		
Sampled by	Analysed by	
Signature	Signature	

<b>Section 3: Final conclusion</b>	
1. Conclusion	
<input type="checkbox"/> Anti-fouling system is compliant with the AFS Convention 2001. <input type="checkbox"/> Anti-fouling system is NOT compliant with the AFS Convention 2001.	
2. Comments	
3. Test organization	
3.1 Name _____	3.2 Date _____
3.3 Signature	
4. Authorized surveyor	
4.1 Name _____	4.2 Date _____
4.3 Signature (Seal or stamp of IS Class)	

**ANNEX 2 AMENDMENTS TO THE INTERNATIONAL  
CONVENTION ON THE CONTROL OF HARMFUL  
ANTI-FOULING SYSTEMS ON SHIPS, 2001**

**Amendments to Annex 1 and Annex 4  
(Controls on Anti-fouling Systems and Surveys and Certification Requirements for  
Anti-fouling Systems)**

**Annex 1 Controls on anti-fouling systems**

1. The following rows are added to the table in Annex 1 to the 2001 AFS Convention:

<b>Anti-fouling system</b>	<b>Control measures</b>	<b>Application</b>	<b>Effective date</b>
Cybutryne CAS No. 28159-98-0	Ships shall not apply or re-apply anti-fouling systems containing this substance	All ships	1 January 2023
Cybutryne CAS No. 28159-98-0	Ships bearing an anti-fouling system that contains this substance in the external coating layer of their hulls or external parts or surfaces on 1 January 2023 shall either: (1) remove the anti-fouling system; or (2) apply a coating that forms a barrier to this substance leaching from the underlying non-compliant anti-fouling system.	All ships except: (1) fixed and floating platforms, FSUs, and FPSOs that have been constructed prior to 1 January 2023 and that have not been in dry-dock on or after 1 January 2023; (2) ships not engaged in international voyages; and (3) ships of less than 400 gross tonnage engaged in international voyages, if accepted by the coastal State(s).	At the next scheduled renewal of the anti-fouling system after 1 January 2023, but no later than 60 months following the last application to the ship of an anti-fouling system containing cybutryne

**Annex 4 Surveys and certification requirements for anti-fouling systems**

2. Regulation 2(3) is replaced by the following:

“(3) For ships bearing an anti-fouling system controlled under Annex 1 that was applied before the date of entry into force of a control for such a system, the Administration shall issue a Certificate in accordance with paragraphs (1) and (2) of this regulation not later than two years after entry into force of that control. This paragraph shall not affect any requirement for ships to comply with Annex 1.”

**Appendix 1 to Annex 4 Model form of International Anti-fouling System Certificate**

3. The section of the model form of the International Anti-fouling System Certificate (appendix 1) listing the compliance options for controlled anti-fouling systems on the ship is replaced by the following:

“An anti-fouling system controlled under Annex 1 containing:

	<b>Has not been applied during or after construction of this ship</b>	<b>Has been applied on this ship previously, but has been removed by</b>	<b>Has been applied on this ship previously, but has been covered with a sealer coat applied by</b>	<b>Has been applied on this ship previously, but is not in the external coating layer of the hull or external parts or surfaces on</b>	<b>Was applied on this ship prior to</b>
Organotin compounds which act as biocides	<input type="checkbox"/>	..... (insert name of the facility) on ..... (dd/mm/yyyy) <input type="checkbox"/>	..... (insert name of the facility) on ..... (dd/mm/yyyy) <input type="checkbox"/>	Not applicable	Not applicable
Cybutryne	<input type="checkbox"/>	..... (insert name of the facility) on ..... (dd/mm/yyyy) <input type="checkbox"/>	..... (insert name of the facility) on ..... (dd/mm/yyyy) <input type="checkbox"/>	1 January 2023 <input type="checkbox"/>	1 January 2023, but must be removed or covered with a sealer coat prior to ..... (dd/mm/yyyy) <input type="checkbox"/>